

# PD-803 Pec/Rear Delt

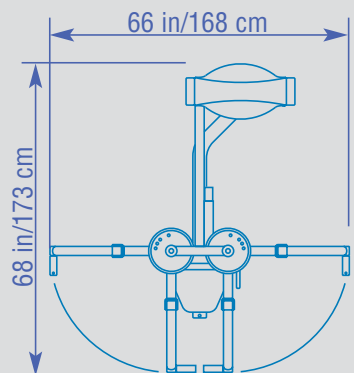

- Self-adjusting swivel handles with fully actuating press arms ensure a uniform and natural movement
- Rotary, independent arm mechanism provides equal loading and synchronizes for unilateral movement
- Overhead adjustment allows quick and easy selection of start position
- Dual-linkage gas assist seat adjustment
- Adjustable back/chest pad support
- 200 lbs. steel weight stack



Ht: 78 in/198 cm  
Wt: 400 lb/181 kg