

PD-807 Inner/Outer Thigh

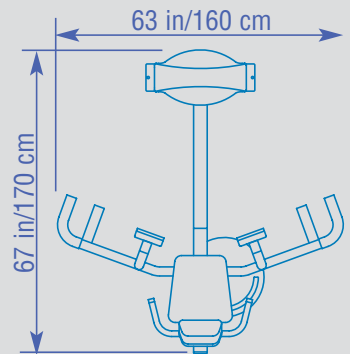

- Conveniently located lever adjustment for the range of motion and starting position for both exercises
- Frontal exercise positioning provides privacy
- Swivel knee pads maintain constant support throughout the range of motion, and minimize torque on the knees
- Dual footpegs design to accommodate different leg lengths
- 150 lbs. steel weight stack



Ht: 55 in/140 cm
Wt: 500 lb/227 kg