

PL-405 Supine Press

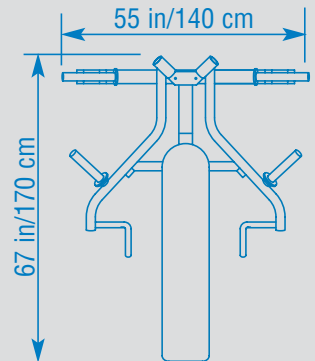

- Converging press arm movement
- Independent, unilateral arm action promotes equal and balanced muscles development
- Adjustable gas assist start/end position allows user's limit range of motion and safety
- Built-in Olympic weight storage



Ht: 51 in/130 cm
Wt: 180 lb/82 kg