

PL-465 35-Degree Hack Squat

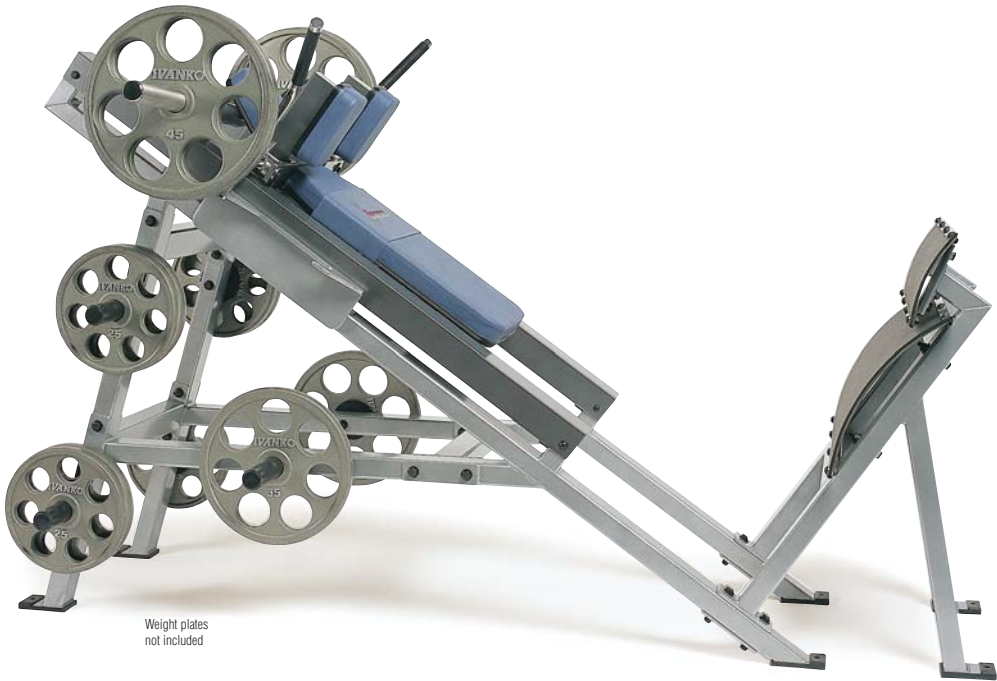

Weight plates
not included

- Dual self-aligning 1-1/2" linear bearing system
- 1-1/2" precision ground tempered steel shaft
- Dual-concave footplate design assures correct leg positioning throughout the range of motion and for variation of exercises
- 35-degree weight carriage travel with fully padded back support, head rest and shoulder pads
- Dual safety catch and release handles for safe start and end position
- Built-in Olympic plate holders

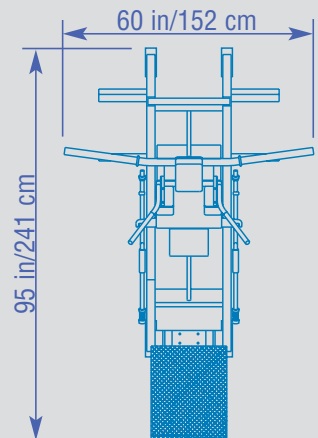

Ht: 61 in/155 cm
Wt: 500 lb/227 kg