

PS-204 Incline Press

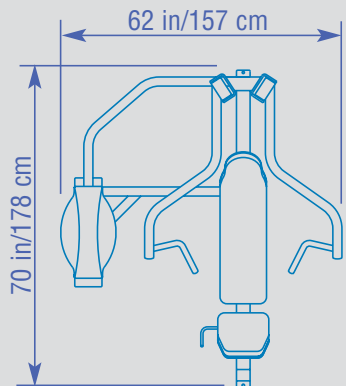

Shown with Lexan see-through protective weight shields

- Biomechanically correct incline angle allows you to fully concentrate on the desired muscle groups and reducing back strain
- Converging press arm movement
- Dual-linkage gas assist seat adjustment
- Pre-stretch foot lever for start and end position
- 200 lbs. steel weight stack



Ht: 55 in/140 cm
Wt: 600 lb/272 kg