

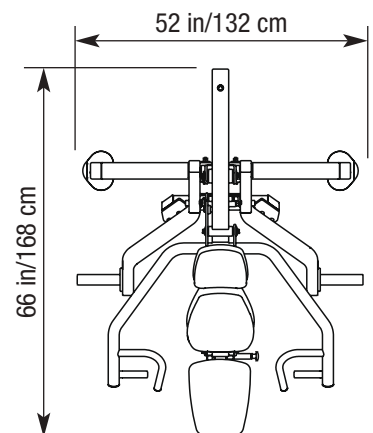

Multi Press | PPL-110

- Adjustable start range on the press arm designed to fit most body types with preset chest and shoulder positions.
- Overhead pivot closely matches free weight lifting.
- Bench seat easily adjust from chest to shoulder press.
- Press arm is counter-balanced to 0 lb. starting weight.
- Multi-grip handles provide neutral grip preferences.
- Main frame structures are 2"x3" 11-gauge rectangular tubular steel with a combination of 2"x2" square and 2" round tubular steel.
- Two tone finish, choice of 7 primary colors on the main frame with standard Charcoal Texture accent.
- Choice of 16 upholstery colors premium naugahyde that is antimicrobial, abrasion/stain-resistant and fire-retardant.
- 12-inch length weight prongs (Olympic plates).
- Weight capacity: 600 lbs.

Finish as shown:
Wrinkle Black and Charcoal Texture



Ht: 55 in/140 cm

NOTE: Dimensions are rounded to the nearest inch and centimeter

NOTICE: TuffStuff continually engages in research related to product improvement. As a result, the product received by the customer may differ slightly from its published description. Improvements in materials, production techniques and design refinement may at any time be introduced into our products. TuffStuff reserves the right to make changes in its product without notice.