



## Prone Leg Curl | PPL-150

- Angled hip and chest pads are designed for prone position to minimize spinal hyperextension.
- Adjustable footroll to accommodate different leg length without affecting knee alignment with the axis of rotation.
- Counter-balanced resistance cam for 0 lb. start position.
- Mectral steel reinforced Kevlar® belt transport system.
- Main frame structures are 2"x3" 11-gauge rectangular tubular steel with a combination of 2"x2" square and 2" round tubular steel.
- Two tone finish, choice of 7 primary colors on the main frame with standard Charcoal Texture accent.
- Choice of 16 upholstery colors premium naugahyde that is antimicrobial, abrasion/stain-resistant and fire-retardant.
- 12-inch length weight prongs (Olympic plates).
- Weight capacity: 600 lbs.

Finish as shown: Wrinkle Black and Charcoal Texture

**NOTICE:** TuffStuff continually engages in research related to product improvement. As a result, the product received by the customer may differ slightly from its published description. Improvements in materials, production techniques and design refinement may at any time be introduced into our products. TuffStuff reserves the right to make changes in its product without notice.

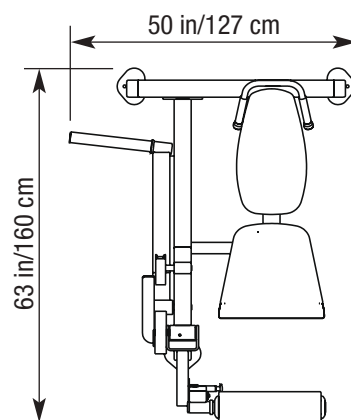

Ht: 28 in/71 cm

**NOTE:** Dimensions are rounded to the nearest inch and centimeter