

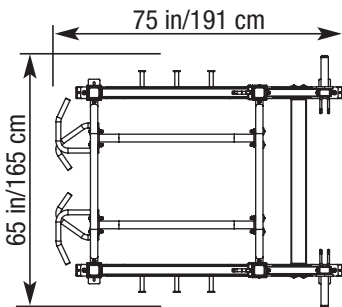

www.tuffstufffitness.com

PXLS-7930 POWER RACK



Height: 97 in/246 cm
Weight: 630 lb/286 kg

ACCESSORIES & PLATFORMS

- PXLS-7923.1 6x8' Olympic Platform – All Rubber
- PXLS-7926.1 6x8' Olympic Platform – Oak Wood
- PXLS-7994 Horizontal Bumper Rack
- PXLS-7996 Spotter Platform (pair)
- PXLS-7997 Landmine
- PXLS-7998 Dip Attachment
- PXLS-7999 Dual Bar Catches

PXLS-7922.1 Olympic Platform with inset (All Rubber) Wt: 530 lb/240 kg

PXLS-7925.1 Olympic Platform with inset (Oak Wood as shown) Wt: 470 lb/213 kg



- 3"x 3" 7-gauge and 2"x3" 11-gauge tubular steel construction.
- Power rack design features adjustable full length, reinforced Lever Lock Safety Rails (rated to 900 lbs. weight capacity).
- Integrated J-hook design (U. S. Patent) featuring quick change 1" solid steel Swing Lock bar catches.
- Durable-welded knurled zinc plated multi-grip pull-up station for wide, narrow, reverse and neutral grip upper body exercises.
- Dual 2" fat bar frame connectors double as additional pull-up station and structural stability.
- Proprietary 8-step electrostatically applied powder coat finish, oven baked to insure durability.
- Deep penetrating electrically welded high strength frames.
- 3/8" and 1/2" grade 5 & 8 frame bolts used for optimum strength and durability.
- Heavy duty weight horns provide ample room to store weight plates of all sizes.
- Storage hooks, suspension loops and power band pegs offered as standard features.
- Two built-in Olympic bar storage keeps bars within easy reach.
- Multiple-layer design, 2" thick platform and inset available with 3/4" solid oak hardwood center or all rubber. Available for all models.
- All frames designed to anchor to floor. Refer to your Owner's Manual for anchoring requirements.
- Custom two tone finish offers choice of seven primary colors: (1) Charcoal Texture (2) Platinum Sparkle (3) Red Baron II (4) Sky White (5) Twilight Blue (6) Matte Black (7) Wrinkle Black Custom colors available – inquire with your sales representative.



- Engineered and manufactured in USA.

COMMERCIAL WARRANTY

- 10 YEARS:** Structural frame (coating excluded) and welds.
- 1 YEAR:** Pull-pin components and platform/inset (surface finish excluded).
All other parts not mentioned, one (1) year from the date of purchase to the original purchaser.
- 90 DAYS:** Platform surface finish, custom platform logo and rubber mat. Finish – applies only to defects from manufacturer only.
See Owner's Manual for details.

